

THIS INFORMATION IS CONFIDENTIAL AND IS DISCLOSED TO YOU ON CONDITION THAT NO FURTHER DISCLOSURE IS MADE BY YOU TO OTHER THAN TOP-LINK PERSONNEL WITHOUT WRITTEN AUTHORIZATION FROM TOP-LINK LTD.

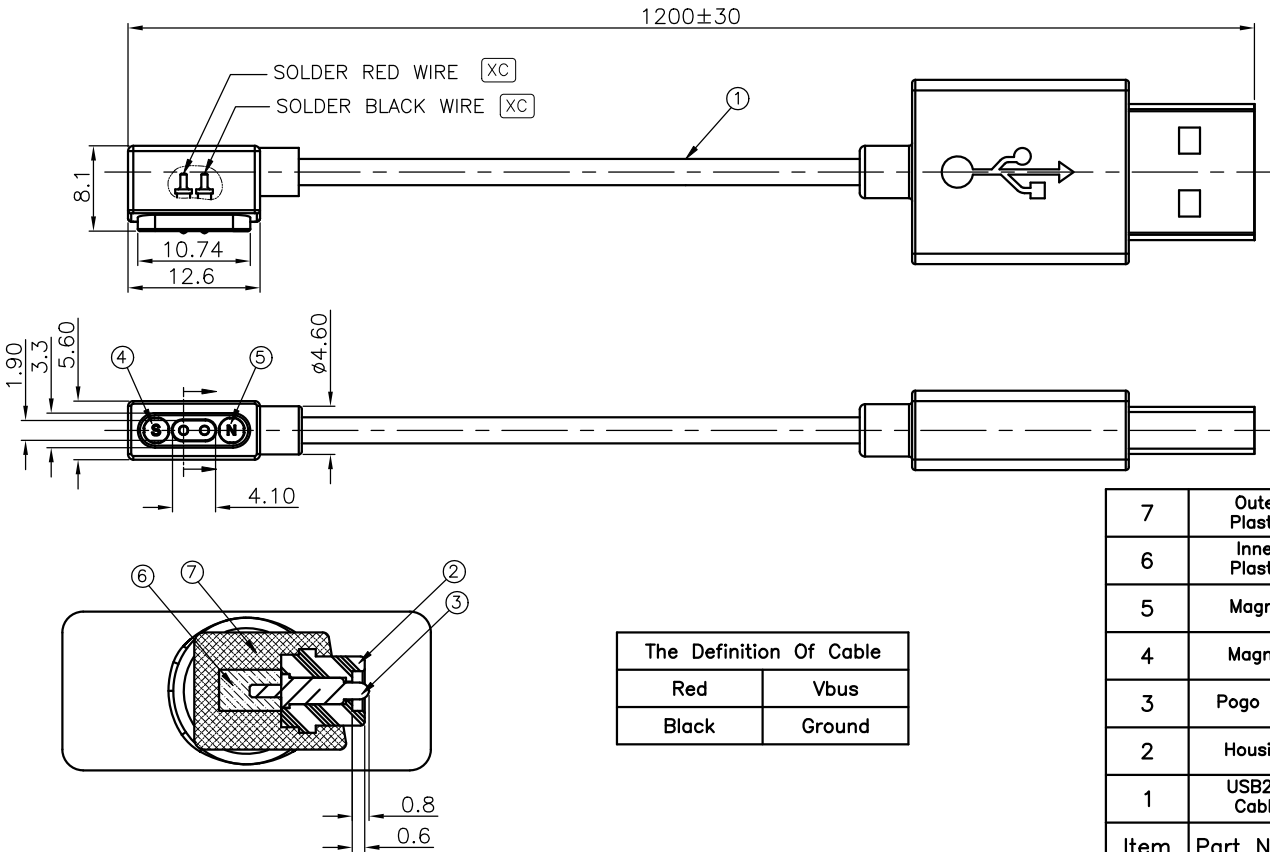
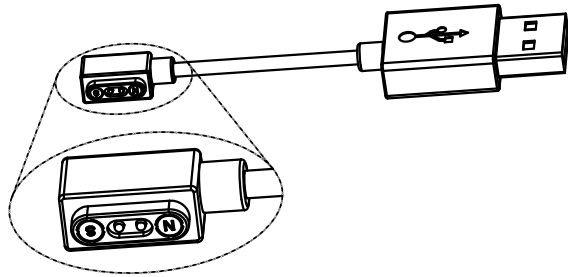

The Definition Of Cable	
Red	Vbus
Black	Ground

XC	update the assignment of pogo pin	2017.11.28
XB	update the surface finish of magnet	2017.11.21
XA	New Release	2017.06.12
Item	Revision record	Date

Top-Link Electronics Ltd.
 TOLERANCES UNLESS OTHER SPECIFIED
 0. = ± -
 0.0 = ± 0.25
 0.00 = ± 0.20
 0.000 = ± -
 Angle: ±1°
 SURF TEXTURE:
 REMOVE BURRS.
 BREAK SHARP EDGES
 R0.05 MAX.DO NOT SCALE PRINT.

Notes:

- 1 Dimensions shall be interpreted per ASME Y14.5M
- 2 Mechanical performance(See the table 1)
 - <2.1>The force is the average of forces obtained when plunger goes downwards and upwards
 - <2.2>Warning:Working height are not permitted to be less than Min working height
- 3 Electrical performance
 - <3.1>Current rating: 0.5A
 - <3.2>Voltage rating: 36VAC/DC
 - <3.3>Contact Resistance:30mOhm Max (at working height)
 - <3.4>Insulation Resistance:10MOhm minimum
- 4 Environmental performance
 - <4.2>Operating Temperature range:-40°C~+85°C
- 5 Environmental protection requirement
 - <5.1>RoHS compliant
- 6 Packaging:Bag

Item	Part Name	Q'TY	Material	Finish
7	Outer Plastic	1pcs	PVC 45P,Black	-----
6	Inner Plastic	1pcs	PP,Transparent	-----
5	Magnet	1pcs	N52,head face was N-pole	Epoxy Black
4	Magnet	1pcs	N52,head face was S-pole	Epoxy Black
3	Pogo pin	2pcs	The stroke was 0.7mm	Gold plating
2	Housing	1pcs	High temperature resistance ,Black	-----
1	USB2.0 Cable	1pcs	2 Pole and the wire diameter was 2.5mm,Black	-----

Type	Customer drawing	Unit	mm	
DRW:	Jackbin Zou	APRD:	Henry	
CHK:	/	REL:		
Name	2pin Cable			
Scale	1:1	Size	A4	
Part NO.	10501020044		Page	1/1
Rev:	XC			

